



August 2008

VIRGINIA POLYTECHNIC INSTITUTE  
AND STATE UNIVERSITY

# Emergency Action Plan



**Weed Science Building  
433A Glade Road Research Facility**

EMERGENCY ACTION PLAN  
**DEPARTMENT OF Plant Pathology, Physiology,**  
**and Weed Science**  
**Weed Science Building**  
**Glade Road Research Facility**

## INTRODUCTION

No one expects an emergency or disaster to affect him or her—or the work area. Yet the reality is that emergencies and disasters can strike anyone, anytime and anywhere. A workplace emergency is an unforeseen situation that: threatens students, staff, faculty and visitors; disrupts or shuts down part or all of the university community; or causes physical or environmental damage. Emergencies may be natural or manmade and include the following:

- Earthquakes,
- Fires,
- Floods,
- Hurricanes,
- Tornadoes,
- Toxic gas releases,
- Chemical spills,
- Radiological accidents,
- Explosions,
- Civil disturbances
- Workplace violence
- Extended utility outages

When an emergency strikes, our immediate safety and prompt recovery will depend on the level of preparedness among faculty, staff and students. At Virginia Tech, planning ahead for emergencies is part of normal business planning and campus life, and all members of the campus community share a responsibility for preparedness.

This emergency action plan (EAP) details the actions that employees in our department are expected to take in response to an emergency. It identifies certain individuals that have an emergency response role. Finally, the EAP is part of our departmental emergency plan, which provides a structure for coordinating the department's actions with our {*Dean, Vice President, or Vice Provost*} at the Satellite Operations Center (SOC) and personnel at the university Emergency Operations Center (EOC) if a large-scale disaster occurs.

### Emergency Coordinators

**Name:** Dr. Shawn Askew  
**Title:** Associate Professor  
**Phone:** 540-231-5807      **Email:** [saskew@vt.edu](mailto:saskew@vt.edu)

**Name:** Julie Keating  
**Title:** Program Support Technician  
**Phone:** 540-231-5835      **Email:** [keatingj@vt.edu](mailto:keatingj@vt.edu)

This person should be contacted with any questions about this Emergency Action Plan. Questions related to emergency planning should be addressed to Environmental, Health and Safety Services at 231-5985 or [firesafe@vt.edu](mailto:firesafe@vt.edu).

## Emergency Action Plan

### Emergency Response Team

The following individuals at the Glade Road Research Facility serve on the PPWS emergency response team:

Name: <u>Lloyd Hipkins</u>	Phone: <u>231-9842</u>	Email: <a href="mailto:lhipkins@vt.edu">lhipkins@vt.edu</a>
Name: <u>Dr. Scott Hagood</u>	Phone: <u>231-6762</u>	Email: <a href="mailto:shagood@vt.edu">shagood@vt.edu</a>
Name: <u>Dr. Ruth Grene</u>	Phone: <u>231-6761</u>	Email: <a href="mailto:grene@vt.edu">grene@vt.edu</a>
Name:	Phone:	Email:

This team disseminates emergency instructions and warnings, assists with evacuations and security, provides first aid and similar support if necessary, and deals with immediate salvage and preservation issues (e.g. moving animals and plants, covering books and equipment).

### Additional Duties

Certain persons may have additional duties under this plan. These duties may include assisting others during the evacuation, performing head counts at the assembly point, or shutting down hazardous equipment or operations. Below is a list detailing any additional duties and the person(s) responsible for performing them:

**Lloyd Hipkins will check emergency evacuation roster upon evacuation.**

### Departmental Emergency Communications

If a large-scale disaster occurs, the department will establish a departmental 'hotline' to answer questions and provide guidance on response. The departmental 'hotline' number is: **231-6361**

Under these conditions, **All those located at the Glade Road Research Facility** will establish an emergency headquarters at **435 Old Glade Road**, reachable by phone at **231-5835** or fax **231-5755**. If the phone system is not operational, check Virginia Tech's web page for information or send a runner to the departmental headquarters.

If a small scale disaster occurs only in the Weed Science Building, the department will establish an emergency headquarters in **the foyer of 435 Old Glade Road**.

The department may also distribute information and instructions via phone mail, email or the departmental web page.

**For immediate building emergencies such as fires, the normal procedure for sounding the alarm is to knock on doors and yell fire or similar as you leave the area.**

### University Emergency Communication Systems

The university maintains a robust emergency communications system, including:

- **VT Alerts.** VT Alerts is Virginia Tech's urgent notification system, comprised of a variety of methods by which the university can contact students, faculty, and staff. You are encouraged to subscribe to this system at the following website, [www.alerts.vt.edu/](http://www.alerts.vt.edu/). Alerts can be sent via: Text messages (SMS) to mobile devices; Instant messages (AOL, MSN, and Yahoo); Calls to home, office, or mobile phone numbers; and, E-mails to non-Virginia Tech addresses
- **Emergency Alert Siren System.** When emergency conditions present a danger to persons outdoors, Virginia Tech may activate its siren system. The sirens can broadcast

## Emergency Action Plan

both tone and voice messages. When the siren is heard, individuals should immediately go inside and consult a source of information (see following).

- Information posted to the university homepage, [www.vt.edu](http://www.vt.edu), and Virginia Tech News, [www.vtnews.vt.edu](http://www.vtnews.vt.edu).
- Information sent using campus-wide e-mail.
- Information broadcast on WVTF-FM 89.1 and other public media outlets.
- Information recorded on the university hotline (231-6668).

### Evacuations

If the building is evacuated in response to a fire or similar emergency, all personnel are to report to a pre-designated assembly point. At the assembly point, supervisors account for personnel and report any that are unaccounted for to the Emergency Coordinator, local police and/or the fire department.

The designated assembly point for this building is **the fairway located to the left of 435 Old Glade Road.**

### Identified Hazards in this Workplace

Below list any special hazards and any required special knowledge and/or training for occupants working in this building: **There are no unusual materials.**

### Persons with Disabilities

If you are a person with a disability—even a short-term disability—that could hamper your ability to evacuate the building during an emergency or prevent you from taking needed action to protect your safety, you are encouraged to self-identify to the Departmental Emergency Coordinator. This person will work with you to incorporate your needs into the planning process.

## Training

Employees must receive training on all elements of the EAP upon its initiation. New employees must receive training when first assigned to the Department. Additional training is necessary when an employee's required actions under the plan change or when there are changes to the plan.

Employees that are designated as Emergency Response or Emergency Recovery personnel may require additional training. This training will be arranged by the Emergency Coordinator for the department.

Departments are encouraged to practice their plan on an annual basis by performing fire or other emergency drills.

### Additional Information

Additional information on emergency planning can be found on EHSS's website at [www.ehss.vt.edu](http://www.ehss.vt.edu).

## Satellite Operations Center (SOC) Organization

Update the information at least annually. Last Revised on:

<b>Primary SOC location (room/building): 104 Hutcheson Hall</b>				
<b>Alternate SOC location (room/building): 435 Old Glade Road</b>				
<b>SOC SENIOR MANAGER</b> Sharron Quisenberry, Dean	PHONE 540 231 4152	EMAIL sharronq	HOME PHONE # 540 382 7162	PAGER (P)/CELLULAR (C) (P) 540 577 2567 (C)
Designated SOC Coordinator Martin Daniel, Director of Operations	540 231 5900	danielmp	540 953 3852	(P) 540 357 2020 (C)
Alternate SOC Coordinator Craig Nessler, VAES Director	540 231 2651	cnessler	540 951 3772	(P) 540 320 6335 (C)
<b>EMERGENCY COMMUNICATIONS SYSTEMS</b>				
<b>Primary SOC Phone #s:</b>	540 231 4152	Cell Phone: 540 357 2020	Fax #: 540 357 4163	Email: danielmp
	540 231 6336	Cell Phone: 540 320 6335		
<b>Alternate SOC Phone #s</b>	540 231 7703	Cell Phone: 540 357 2020	Fax #: 540 231 5755	Email: cnessler
	540 231 6761	Cell Phone: 540 320 6335		
<b>VOICEMAIL NOTIFICATION GROUPS</b>	<b>PURPOSE</b>	<b>ACCOUNT (PHONE NUMBER)</b>	<b>ACCESS CODE</b>	<b>DISTRIBUTION LIST TO USE</b>
	For SOC to activate key staff			
	To send recorded bulletins to constituents from SOC VP/Dean/Director			
	Other (define):			
<b>Email notification lists</b>	Who has access to the lists/account: General Access		Backup: CALS-ALL@LISTSERV.VT.EDU	
<b>SOC "Hotline" Number</b>				
Other communications means (radio or ham resources)? If yes, identify where the equipment is stored, who is qualified to operate, and how this is activated. None		Inventoried equipment/storage location: Operators' Names: Phone/Pager Numbers: None		

# DEPARTMENT EVACUATION ROUTES

Weed Science Building  
433A Glade Road Research Facility

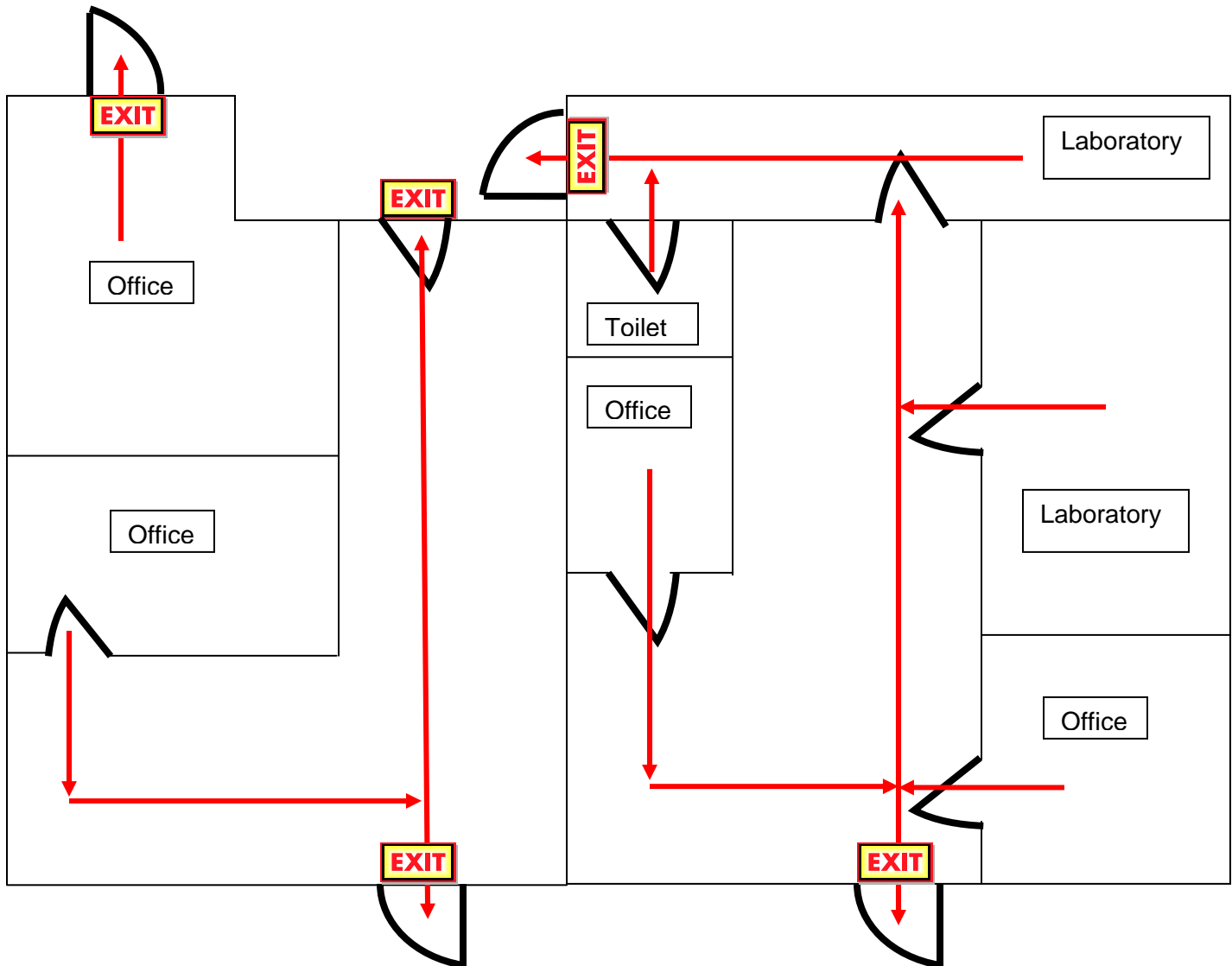

# Emergency Action Plan

In case of emergency requiring evacuation of building the assembly point will be at the fairway next to 435 Old Glade Road.

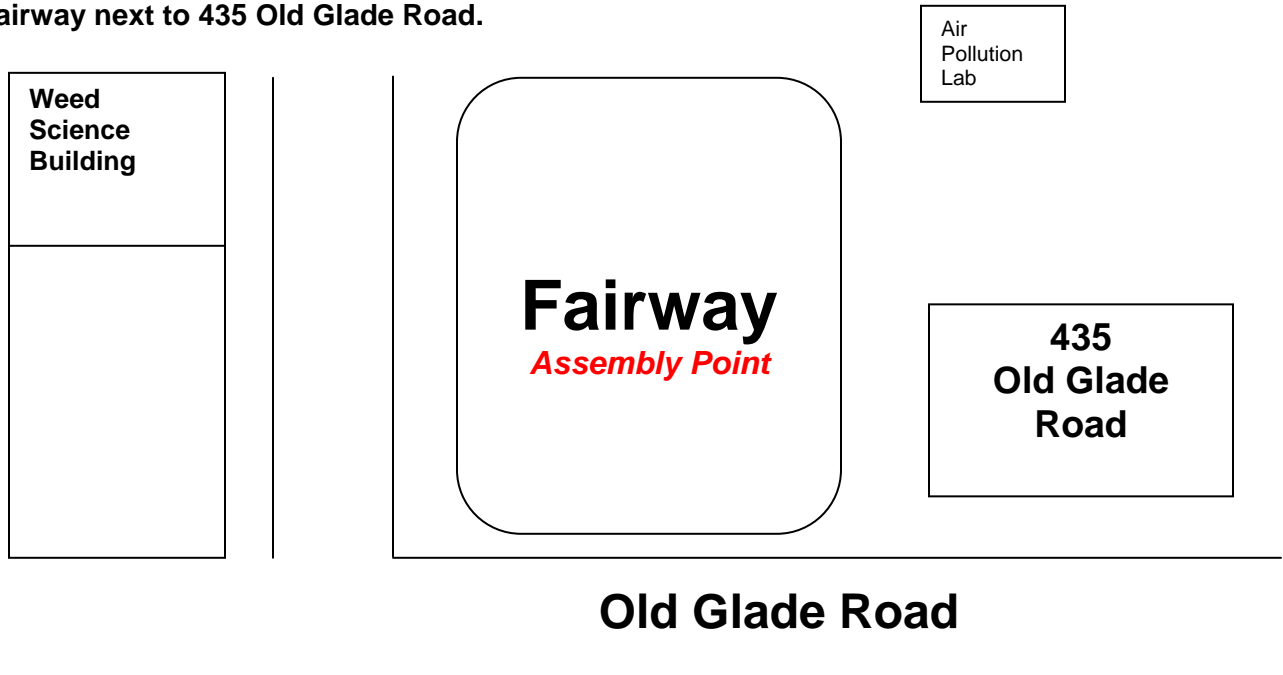

In case of emergency requiring lock down the assembly point for the Aquatic and Non-Crop Weed Science Building will be in the Central Office.

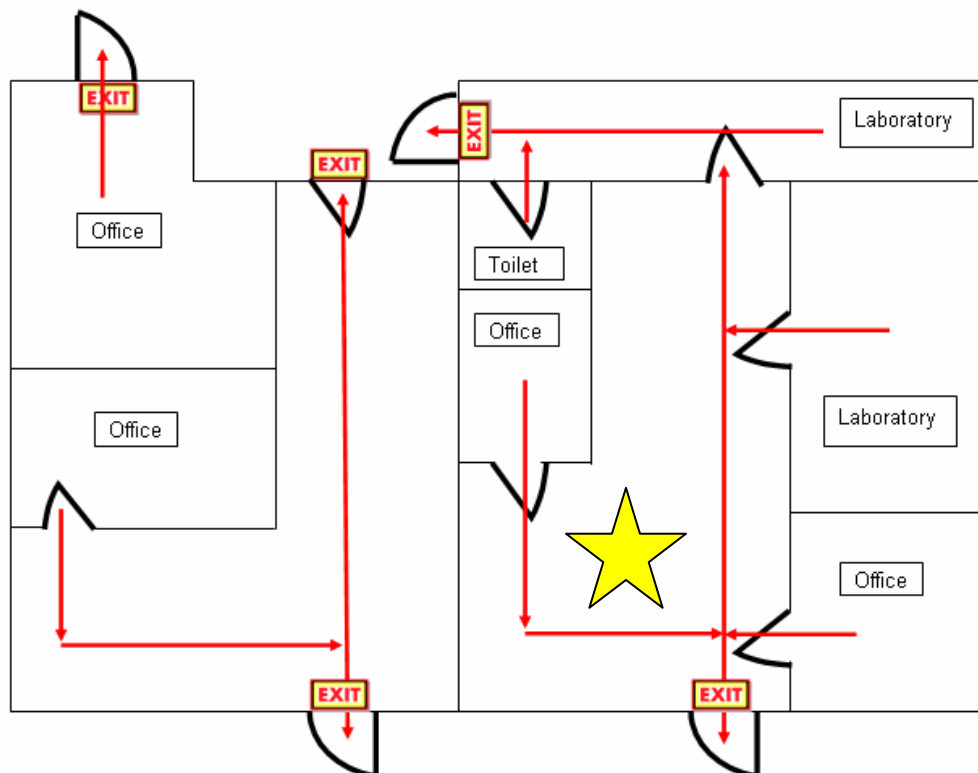

## EMERGENCY RESPONSE ACTIONS

### Medical Emergency Procedure

- Notify Virginia Tech Police of the location, nature and extent of the injury by calling 911. Always call from a safe location.
- Protect the victim from further injury by removing any persistent threat to the victim. Do not move the victim unnecessarily.
- Provide first aid until help arrives if you have appropriate training and it is safe to do so.
- Send someone outside to escort emergency responders to the appropriate location, if possible.

### Evacuations

If the building is evacuated in response to a fire or similar emergency, all personnel are to report to the pre-designated assembly point. At the assembly point, supervisors account for personnel and report any that are unaccounted for to the Emergency Coordinator, Virginia Tech Police and/or the fire department.

#### **To Assist Visually Impaired Persons:**

- Announce the type of emergency.
- Offer your arm for guidance.
- Tell the person where you are going, obstacles you encounter.
- When you reach safety, ask if further help is needed.

#### **To Alert People with Hearing Problems:**

- Turn lights on/off to gain the person's attention, or
- Indicate directions with gestures, or
- Write a note with evacuation directions.

#### **To Evacuate People Using Crutches, Canes, or Walkers:**

- Evacuate these individuals as injured persons.
- Assist and accompany to evacuation site if possible, or
- Use a sturdy chair (or one with wheels) to move the person, or
- Help carry the individual to safety.

#### **To Evacuate Wheelchair Users:**

- Non-ambulatory persons' needs and preferences vary. Individuals at ground floor locations may exit without help. Others have minimal ability to move. Remember, lifting may be dangerous to you or them.
- Some non-ambulatory persons have respiratory complications. Remove them from smoke and vapors immediately. Wheelchair users with electrical respirators should get priority assistance.
- Most wheelchairs are too heavy to take down stairs. Consult with the person to determine best carry options and reunite the person with the chair as soon as it is safe to do so.

## Emergency Action Plan

Do not put yourself or others in danger. If you cannot safely evacuate an individual, get them to a stairwell or other easily identified "protected" location and notify emergency responders as soon as possible of the individual's situation and location.

**During an emergency, students and visitors who may not be familiar with this plan must be informed of the requirement to evacuate.**

Note that it may or may not be necessary to vacate a specific area during an emergency incident. Occupants in the area may simply be directed to remain on-site and shut down systems, or they may be asked to move to other sectors of their floor or building. In some events (such as extended power outages), evacuations are not necessary unless the incident has generated an immediate health and safety risk. Follow all directions from emergency response personnel.

**For broad-scale emergencies that affect a large portion of the campus, wait for evacuation instructions from the SOC, the EOC or the university administration,** and engage the unit's Emergency Response Team to communicate the information throughout the unit. Campus evacuations will be directed by the Virginia Tech Police Department to maintain safety and avoid traffic gridlock. Under these circumstances:

- Remain calm.
- Alert Emergency Response Team to assist with evacuation.
- Quickly shutdown any hazardous operations or processes and render them safe.
- Follow directions to the evacuation site.
- Walk, do not run.
- Do not use elevators.
- Take personal items.
- Notify others in the unit's area of the alarm if they did not hear it.
- Assist persons with disabilities.
- Check offices, classrooms, and restrooms.
- Turn equipment off, if possible.
- Close doors.
- Take emergency supplies and employee rosters.
- Keep exiting groups together.
- Instructors assist students.
- Gather at the evacuation site and await instructions.
- Account for faculty, staff and students.
- Report any missing or trapped people to the emergency responders.

### **Shelter-in-Place**

There may be situations when it's simply best to stay where you are and avoid any uncertainty outside. There are other circumstances when staying put and creating a barrier between yourself and potentially contaminated air outside, a process known as "shelter-in-place," is a matter of survival. **An order to shelter-in-place would be given to your department via your SOC, or announced by the EOC or the university administration by email, phone messages, or updates on the Virginia Tech website.**

## Emergency Action Plan

If told to shelter in place:

- Stay in a building or other shelter until otherwise directed or the danger has subsided.
- If you are outdoors, go inside immediately.
- Close all windows and doors, and follow any other instructions that are issued.

## Fire Emergencies

### SOUND THE ALARM

- If you discover or suspect a fire, sound the building fire alarm.
- If there is no fire alarm in the building, warn other occupants by knocking on doors and shouting “fire” as you leave the building or use other prepared methods as outlined in this EAP.

### EXITING A ROOM

- Before opening any door, feel the doorknob with the back of your hand. Do not open the door if it is hot.
- Brace yourself behind the door, crouch low, and open the door slightly if it is warm.
- Stay low if the area is smoky. If heat or heavy smoke is present, close the door and stay in your room.

### LEAVE THE BUILDING

- Try to rescue others **ONLY** if you can do so safely.
- Move away from the building and out of the way of the fire department.
- Go to your department’s designated assembly point.
- Don’t go back into the building until the fire department says it is safe to do so.

### CALL THE FIRE/POLICE DEPARTMENT

- Dial 911 or use an “emergency” phone.
- Give as much information as possible to the 911 operator.

You may attempt to put out the fire if you have been trained in and are comfortable using a fire extinguisher. Otherwise, immediately evacuate. Hazardous equipment or processes should be shut down before leaving unless doing so presents a greater hazard. Remember to close all doors.

Assist anyone who may be in danger, if you can do so without endangering yourself. Exit the building in a calm manner using the stairs - **never use elevators**. After you have left the building, go to your pre-designated assembly point and remain there. Remain outside the building, even if the alarm is silenced, until the fire department has given the “all clear”.

Maintain a safe distance from the building, about 50 feet, to allow ample room for emergency personnel and equipment to access the building.

### If primary and alternate escape routes are blocked:

- Go back to your room, close the door and call 911 to report your location.
- Seal the cracks around the door to prevent smoke from entering.
- Open the window a few inches for fresh air and hang a brightly colored cloth or bed sheet out the window to alert the Fire Department to your location. If you have a flashlight, use it to signal at night.

## Emergency Action Plan

- If smoke gets in your room, keep low and dampen a cloth with water, place it over your nose and breath lightly through it.
- Stay calm. Do not jump from windows above the second floor. Rescue personnel have the proper equipment to get to you quickly.

### **WEATHER EMERGENCIES**

Weather emergencies can pose serious threats to university personnel. When severe weather occurs, the administration will determine whether university offices will be closed. Check Virginia Tech's web page, call the weatherline (231-6668), or listen to local TV and radio news broadcasts for this information.

Follow these recommendations if severe thunderstorms, threatening weather or tornadoes occur during the workday:

- If weather conditions appear threatening, listen for an ALERT WARNING through commercial radio, weather radio or local television.
- If you are outside, move indoors as soon as possible.
- Move to an interior hallway or basement if time allows, or take shelter under a desk or heavy table and cover your head.
- Avoid upper floors, large glassed areas and windows.
- Stay out of parking areas, gymnasiums, and auditoriums.
- Stay away from electrical service panels and appliances, including computers.
- Use telephones for emergency calls only.
- During the fall and spring, severe weather emergencies, such as tornados, occur more frequently. Listening to a small, battery-operated radio is a good way to stay informed of such conditions.
- Stay calm and alert.

After a severe storm:

- Report damage on campus to Physical Plant (231-4300) and to Risk Management (231-7439). Report damages on other locations to Satellite Operation Centers. Use extreme caution when entering buildings. Watch for gas leaks, electrical system damage, and sewer and water line damage. Stay out of damaged buildings and return to your building only when authorities say it is safe.
- Stay away from downed power lines. Do not handle live electrical equipment in wet areas. Electrical equipment should be checked by an electrician and dried before being returned to service. Be sure the power is off before entering flooded basements if water is high enough to reach appliance motors or any electrical equipment. Leave an area immediately if you smell gas or vapors from chemicals.
- Help injured persons if you can do so without putting yourself at risk of injury. Provide first aid if you are trained. Report injuries by calling 911. Do not move seriously injured persons unless they are in immediate danger.
- Do not make unnecessary telephone calls in order to leave lines open for emergency calls.
- Do not sightsee or spread rumors.

### **Earthquakes**

While earth tremors do occur in eastern Virginia, it is extremely unusual for one to occur that is noticeable by building occupants, and even more rare for one to occur that is substantial in nature. If an earthquake does occur:

- Take cover immediately (under a desk, table or chair, between seating rows in lecture halls, or against corridor walls).
- If you are outdoors, keep away from buildings, poles or other structures that could overturn.
- Be alert for aftershocks.

#### **Minor Quake (Brief Rolling Motion)**

- Restore calm. Examine your area for damage
- Report damage/hazardous materials releases.
- Await instructions. Evacuations are unlikely.

#### **Major Quake (Violent Shaking)**

- Restore calm. Assist others.
- Report injuries to 911.
- Report damage to executive management.
- Evacuate carefully. Be alert for aftershocks.
- Take emergency supplies.
- Do not use elevators.
- Meet at your designated assembly point.
- Do not enter buildings until they are examined.
- Await instructions, be patient, help others.

### **Hazardous Materials Emergency Procedure**

Minor spills of hazardous chemicals that pose little or no threat to the safety and health of personnel can be cleaned by competent departmental personnel by following the warning and caution signs on the container's label or manufacturer's safety data sheet (MSDS). A Hazardous Materials Emergency exists when cleanup of a spill of a hazardous material is beyond the level of knowledge, training or ability of the staff in the immediate spill area or the spill creates a situation that is immediately dangerous to the life and health of persons in the spill area or facility. Alert people in the immediate area of the spill and evacuate the room.

- Confine the hazard by closing doors as you leave the room.
- Use eyewash or safety showers as needed to rinse spilled chemicals off people.
- Evacuate any nearby rooms that may be affected. If the hazard will affect the entire building, evacuate the entire building.
- Notify University Police of the chemical, location and size of the spill calling 911. Always call from a safe location. Be prepared to spell chemical names. Report the following information:
  - Name and telephone number of the caller.
  - Location of the spill, name and quantity of the chemical.
  - Extent of injuries, if any.

## Emergency Action Plan

- Environmental concerns, such as the location of storm drains and streams.

Procedures for laboratory personnel to handle chemical, biological or radiological spills are provided in laboratory safety plans. Trained laboratory personnel are authorized to determine appropriate emergency responses for their areas.

### Loss of Electric Power

- Take actions to preserve human and animal safety and health. Take actions to preserve research.
- Turn off and/or unplug non-essential electrical equipment, computer equipment and appliances.
- Keep refrigerators and freezers closed throughout the outage to help keep them cold.
- Call Physical Plant Customer Service (231-4300) if a power failure occurs on campus during normal hours. Physical Plant will dispatch an electrician to the scene. If power fails in a building after hours, call the Virginia Tech Police Department at 231-6411. If a power outage occurs on another location, call the local utility company for assistance.
- Evacuate the building if instructed by emergency personnel. Assist other building occupants to move to safe locations. Emergency lighting is provided in halls and stairways to ensure occupants can evacuate the building safely. Turn equipment off as you leave to prevent damage from a power surge.
- Do not use candles or open flame.
- If the laboratory fume hood is non-operational, cap all open containers and close the sash.

### Workplace Violence

If workplace violence occurs:

- Report the incident to the police as soon as you can if they haven't already been contacted.
- Secure the area where the disturbance occurred. The area may be considered to be a crime scene, so leave everything untouched until the police arrive.
- Make sure everyone's okay and that there's no potential for additional injury. Call for medical assistance if necessary.
- If business must continue, shift personnel as needed to cover essential work functions.
- Be supportive. The victim(s), witnesses and other employees may need access to critical incident debriefing or counseling. Contact Personnel Services for guidance or assistance as needed.
- *{Add to this list any special procedures that have been established to address this issue. Reference the guidance in this document for more information, or contact EHSS at 231-5985, the Virginia Tech Police Department at 231-6411, or Personnel Services at 231-9331 for assistance.}*

### Bomb Threat Procedure

During a call remain calm and try to obtain as much information as possible from the caller. Try to write down the caller's exact words. If possible, use the [Bomb Threat Checklist](#) at the end of this plan to record important information such as:

- When is the bomb going to explode?
- Where is the bomb located right now?

## Emergency Action Plan

- What does the bomb look like?
- What kind of bomb is it?
- What will cause the bomb to explode?
- Did you place the bomb?
- Why?
- What is your address?
- What is your name?

Also record the following information:

- Exact time the call is received.
- Information about caller including:
  - Sex - Age – Accent
  - Education - Location of caller - Background noises
  - Caller's attitude - Speech impediments or traits

Immediately call the Virginia Tech Police Department (VTPD) at 231-6411 if the threat is on Blacksburg campus. On other locations call your local police department at 911. Provide the police with the context of the threat, telephone number on which it was received, your name, room number and telephone number where you can be reached. Take no other action unless directed to by the VTPD.

Notify your immediate supervisor that you have received a bomb threat and have called the police. Do not state the nature of the call to anyone else.

Complete the [Bomb Threat Checklist](#). A copy of the checklist is in the Checklist section at the end of this plan. Remain at your location until the police arrive. The officer will interview you regarding the call and take the checklist.

## Suspicious Package Procedure

If you receive or observe a suspicious letter or package that is unexpected or unknown with the following characteristics:

- Excessive postage.
- Misspellings of common words.
- Excessive weight.
- Rigid envelope.
- Foreign mail, airmail or special delivery.
- Hand written or poorly typed address.
- Restrictive markings such as confidential, personal, etc.
- Excessive securing - material such as masking tape, string, etc.
- Incorrect titles.
- Oily stains or discoloration.
- Visual distractions.
- Lopsided or uneven.
- Titles but no names.
- No return address.
- Protruding wires or tinfoil.

## Emergency Action Plan

From a safe location notify the police department immediately by calling 231-6411 (for Blacksburg campus) or 911.

- Move people away from the package.
- DO NOT move or open the package.
- DO NOT investigate too closely.
- DO NOT cover, insulate or place the package into a cabinet or drawer.



## Bomb Threat Checklist

### TELEPHONED THREAT

As soon as a telephoned bomb threat is received, the person answering the telephone should signal a fellow employee to inform the Police Department by calling 231-6411 (for Blacksburg campus) or 911. The person receiving the call should be guided by the following instructions:

1. Remain calm and try to hold the caller on the phone as long as possible.
2. Record exact time and date of call.                      Date: \_\_\_\_\_                      Time: \_\_\_\_\_
3. Record the exact words of the caller.  
\_\_\_\_\_
4. If the caller is interested in talking, encourage him or her to do so by asking questions.
5. When possible, ask caller:
  - a. The time the bomb is set to go off: \_\_\_\_\_
  - b. The location of the bomb (the exact spot if possible), and why it was placed there: \_\_\_\_\_
  - c. The kind of explosive material in the bomb (dynamite, black powder, TNT): \_\_\_\_\_
  - d. How the device will be set off (timing mechanism, heat, radio, etc.): \_\_\_\_\_
  - e. If there is any special way to identify the bomb: \_\_\_\_\_
6. From the voice of the caller, try to determine:
  - a. Sex: \_\_\_\_\_
  - b. Age (child, teenager, adult): \_\_\_\_\_
  - c. Race: \_\_\_\_\_
  - d. Accent: \_\_\_\_\_
  - e. Any speech defects or peculiarities (lisp, stutter, slurred, etc.): \_\_\_\_\_
  - f. What is the manner of the caller (calm, angry, emotional, etc.): \_\_\_\_\_
  - g. Is the caller drunk or on drugs? \_\_\_\_\_
  - h. Is the caller calm, excited, in a hurry? \_\_\_\_\_
  - i. Does the caller seem educated or uneducated (speech habits, word use, language, etc.): \_\_\_\_\_
  - j. Does the caller repeat words or phrases? \_\_\_\_\_
  - k. Does the caller emphasize certain words? \_\_\_\_\_
7. Note any background noises that might help determine the origin of the call, such as:
  - a. Silence
  - b. Animals (dogs barking, farm noise, etc.)
  - c. Street noises
  - d. Airplanes (jet overhead, plane taking off, etc.)

## Emergency Action Plan

<ul style="list-style-type: none"><li>e. Motor running</li><li>f. Office machines</li><li>g. Music, television, or radio program</li><li>h. Dishes rattling</li><li>i. Baby crying, or</li><li>j. People laughing, partying, etc.</li></ul> <p>8. When call is complete, notify the police department (231-6411 or 911) if it has not already been contacted. Write down everything about the call while it is fresh in your memory. Do not discuss the call with anyone unless authorized to do so. The police department will respond immediately. Contact the dean, director or building supervisor and have them meet the police at a pre-determined location at the building.</p> <p>9. Follow the instructions from the Police Department.</p>
<b>WRITTEN THREAT</b>
<p>If a written threat of an explosive device or other danger is received, contact the police department immediately by calling 231-6411 (for Blacksburg campus) or 911. The threat should never be ignored. Save all materials, including any envelope or container. Once the message is recognized as a threat, further unnecessary handling should be avoided. Every effort must be made to retain evidence, such as fingerprints, handwriting or typewriting, paper, and postal marks, which are essential to tracing the threat and identifying the writer.</p>
<b>SUSPICIOUS DEVICE OR PACKAGE</b>
<p>If you receive or observe a suspicious letter or package that is unexpected or unknown with the following characteristics:</p> <ul style="list-style-type: none"><li>• Excessive postage.</li><li>• Misspellings of common words.</li><li>• Excessive weight.</li><li>• Rigid envelope.</li><li>• Foreign mail, airmail or special delivery.</li><li>• Hand written or poorly typed address.</li><li>• No return address.</li><li>• Restrictive markings such as confidential, personal, etc.</li><li>• Incorrect titles.</li><li>• Excessive securing - material such as masking tape, string, etc.</li><li>• Oily stains or discoloration.</li><li>• Visual distractions.</li><li>• Lopsided or uneven.</li><li>• Titles but no names.</li><li>• Protruding wires or tinfoil.</li><li>• A package or container found in a unusual/unexpected location.</li></ul> <p>From a safe location notify the police department immediately by calling 231-6411 (for Blacksburg campus) or 911.</p> <ul style="list-style-type: none"><li>• Move people away from the package.</li><li>• DO NOT move or open the package.</li><li>• DO NOT investigate too closely.</li><li>• DO NOT cover, insulate or place the package into a cabinet or drawer.</li></ul>

## Emergency Procedures for Faculty, Lecturers, and Teaching Assistants

### **Instructor's Responsibilities:**

- Provide his or her class or audience with general information relating to emergency procedures. This information should be shared during the first week of class or at the start of a seminar and should include an overview of evacuation routes, location of the emergency assembly point, and information on the fire alarm system for the building.
- Know how to report an emergency from the classroom being used.
- Assure that persons with disabilities have the information they need. The instructor should be familiar with the disabled student's plan and be able to direct visitors with disabilities.
- Take responsible charge of the classroom and follow emergency procedures for all building alarms and emergencies.

### **As an instructor, what do I need to know about Emergency Preparedness?**

The *instructor* is an authoritative figure for the student, either consciously or subconsciously, and can influence how the student responds in an emergency. Calm, collected, and clear directions by the instructor will have a calming effect on the students. In order for the instructor to exhibit this controlled personae, he or she must be prepared for emergencies.

### **Emergency Evacuation Plans**

Every university department and unit should have a written Emergency Action Plan covering specific procedures for their facility and employees. These plans should cover events such as: fire, earthquake, power outage, bomb threat, hazardous material spills, severe weather, etc. Instructors will find it helpful to review the plans for the buildings in which they teach to see if the plans differ from the general information provided here.

### **Evacuation Routes**

Evacuation floor plans are posted on building walls at main entrances. Use these plans to identify a primary and alternate evacuation route from your classroom.

### **Emergency Assembly Points**

After the class leaves the building or area in response to an alarm, it is important for them to go to a pre-determined area where you can account for all persons in your class. Identify this area while determining your evacuation routes.

### **Accounting for Students**

Accounting for all students can be very difficult, particularly with a large class. However, an attempt must be made. For example, it might be possible for the instructor to: wait until all the students have left the room/lab, use the class roster, use a head count, or have students see if the students seated next to them are at the assembly point. You must also account for persons with disabilities. (See below)

### **Evacuation for persons with Disabilities**

If there is a person with a disability in the class, the instructor must be knowledgeable of their response plan and who may be assisting them. Four options are available to persons with disabilities:

- Horizontal evacuation to the outside or another building, if available.
- Stairway evacuation.
- Stay in place unless danger is imminent.

## Emergency Action Plan

- Area of refuge, if available.

### **Elevators cannot be used during an emergency evacuation!**

#### **Reporting**

After exiting and accounting for students, the instructor will notify emergency personnel of persons missing or trapped or persons with disabilities that are waiting assistance in areas of refuge. Normally the senior police or fire official on site will designate someone to coordinate the collection of information. However, if you have knowledge of someone trapped in the building, immediately bring that to the attention of the authorities.

#### **Fire Alarms**

Fire alarms will be a sound of a slow WHOOP or a HORN and may include strobe lights for people with hearing disabilities. In buildings without a fire alarm system, departments in the building may sound the alarm by shouting 'fire' or by using air horns or similar means. When the alarm sounds, everyone must exit the alarmed area according to the evacuation plan.

- Procedures that may be hazardous if left unattended should be shut down.
- Verify that everyone leaves and that all the doors are closed, but not locked. Closed doors significantly reduce fire and smoke damage.

#### **Earthquakes/Explosions**

Most of the injuries that occur during earthquakes or explosions are caused by interior items, such as books, shelves, light fixtures, ceiling tiles and office equipment, falling on the building occupants. Consequently, the first thing to do during such an event is to have everyone drop to the floor, cover his or her head, and hold that position. After the shaking or explosion stops, and if there is building damage, tell the class to calmly collect their possessions and evacuate the building to the Emergency Assembly Point. Caution them to watch for brick and other exterior building materials that may have been knocked loose by the earthquake or explosion. Procedures that may be hazardous if left unattended should be shut down.

#### **What To Expect In A Power Outage**

Most campus buildings are provided with emergency lights, though these lights are typically only located in hallways and exit stairs. The lights should be operational within 60 seconds following a power outage. Consequently, if the power does go out during class, have the people stay in their seats for a little while and wait for either the power to return or the emergency lights to turn on. If the power does not return in a reasonable length of time, then evacuate the classroom or laboratory. Evacuation should take advantage of available lighting unless the building is in alarm, then use the same evacuation procedures as during a fire. Caution students that there is no rush and they should take their time exiting the building.

#### **How To Report An Emergency**

Check each classroom, lecture hall, or laboratory for the nearest working telephone, the nearest fire alarm pull station, and the nearest fire extinguisher.

- Fire and if possible - Activate Fire Alarm Pull Station, Call 911
- Medical/Police - Call 911
- Hazardous Material Spill - Call 911
- Facility or Utility Failure - Call 231-4300 (for Blacksburg campus only)

#### **What Emergency Preparedness materials should I have with me at class?**

- Required – class roster
- Important telephone numbers (Department Administrator, Classroom Services, Student Services, others as appropriate).

## Classroom Emergency Procedures

### **When you hear the fire alarm...**

- Everyone should calmly collect their coats and books and exit the classroom, lecture hall, or laboratory. Please turn off the gas supplies in laboratories.
- Leave the room/lab and go the nearest building exit. Know the location of alternate exits.
- **The elevators cannot be used during a fire alarm!**
- Go to the Emergency Assembly Point designated by your instructor.  
Exception: Persons with disabilities may choose to remain in place or report to an area of refuge.

### **When there is a power outage...**

- Everyone should stay in their seat to see if the outage is temporary and to let their eyes adjust to the lower light level.
- If the outage appears to be long term, everyone should calmly collect their materials and carefully exit the building.

### **If there is an earthquake or explosion...**

- Drop and cover your head for protection from material that might fall from the ceiling or walls.
- After the shaking stops, calmly evacuate the building and standby for further directions from University officials.

### **In the event of an undefined emergency (terrorist incident, regional hazmat incident, etc)...**

- Remain calm.
- Remain in place unless there is a readily apparent reason to leave the building (i.e. the building is on fire).
- Await instructions from police, fire or university officials on how to proceed.
- Prepare to evacuate the building if it becomes necessary.

### **Important Emergency Numbers (for Blacksburg campus)**

<b>Emergencies (Police, Fire, Rescue):</b>	<b>911</b>
Police (Non-emergency)	540-231-6411
Schiffert Health Center:	540-231-5996
Physical Plant Customer Service:	540-231-4300

## Evacuation Planning For Persons With Disabilities

Form last revised on \_\_\_\_\_

List self-identified disabled persons who request evacuation assistance during an emergency. Designate evacuation assistants to wheelchair users to assist them during an emergency. \*

NAME: \_\_\_\_\_

Room/Building: \_\_\_\_\_

Phone: \_\_\_\_\_

Disability: \_\_\_\_\_

Instructions: \_\_\_\_\_

NAME: \_\_\_\_\_

Room/Building: \_\_\_\_\_

Phone: \_\_\_\_\_

Disability: \_\_\_\_\_

Instructions: \_\_\_\_\_

NAME: \_\_\_\_\_

Room/Building: \_\_\_\_\_

Phone: \_\_\_\_\_

Disability: \_\_\_\_\_

Instructions: \_\_\_\_\_

NAME: \_\_\_\_\_

Room/Building: \_\_\_\_\_

Phone: \_\_\_\_\_

Disability: \_\_\_\_\_

Instructions: \_\_\_\_\_

NAME: \_\_\_\_\_

Room/Building: \_\_\_\_\_

Phone: \_\_\_\_\_

Disability: \_\_\_\_\_

Instructions: \_\_\_\_\_

\* This information is to be maintained by the Departmental Emergency Coordinator, and should not be shared except with those that have been assigned to assist persons with disabilities during a building emergency.

## Emergency Action Plan

### MEMORANDUM

Date:

To: All Employees

From:

Subject: Identifying Employees Needing Assistance During an Emergency

Currently, our Department is in the process of reviewing and updating our Emergency Plan. An essential component in a comprehensive plan is identifying all employees who may need assistance during an emergency. The need for assistance may be permanent or temporary, such as when you are recovering from surgery or a broken leg. When completing this form, evaluate your situation thoroughly and honestly. You might not think you need assistance, but a heart condition, asthma or pregnancy can reduce your stamina to the point where you need assistance during an emergency. Or, your hearing loss might limit your ability to respond to an audio alarm or evacuation information.

Describe in detail the type of assistance you think you will need. **It is not necessary to give medical details.**

If you want colleagues to assist you, you can either select your own or choose from a list of volunteers the department has on file. If you choose your own, list their names and phone numbers. You should select a primary aide and a back-up as well. Make sure you select "emergency aides" who can handle their assigned tasks.

Please complete the attached form and return it to the Emergency Coordinator, \_\_\_\_\_, in room \_\_\_\_\_. The Coordinator will contact you to discuss your request.

This information will be kept confidential according to the Federal Privacy Act (P.L. 93-579). It will be used only to provide assistance during an emergency.

It is our goal to safely and efficiently protect every employee, client and visitor during an emergency and to preserve everyone's personal dignity in the process.

It is our responsibility to provide a safe place for you to work. However, we cannot be held liable for your safety if you do not identify your need for assistance.

Thank you,

Attachment

Emergency Action Plan

VIRGINIA TECH <b>EMERGENCY EVACUATION INFORMATION</b>		DATE:	
Name:		Office Phone Number:	
Building:		Room Number:	
Supervisor:		Office Phone Number:	
<b>Do you need assistance during an emergency? (Circle One)</b>			<b>YES NO</b>
<b>If yes, describe the type of assistance you anticipate needing. Please do not give medical details.</b>			
<b>Do you wish to choose your aides from a list of volunteers? (Circle One)</b>			<b>YES NO</b>
<b>If no, list the names and phone numbers of two coworkers you wish to assist you:</b>			
Name:		Phone No.:	
Name:		Phone No.:	
<b>Do you wish to be evacuated during drills or minor emergencies? (Circle One)</b>			<b>YES NO</b>
If you do not wish to be evacuated, go to an area of refuge during drills or minor emergencies.			
The purpose of this form is to identify employees who need assistance during an emergency. The need may be permanent or temporary such when an employee is recovering from surgery or a broken leg. Some employees may not think they have a disability, but a heart condition, asthma or pregnancy can reduce stamina to the point of needing assistance when quickly moving down stairs. Or, a person's hearing loss might limit the ability to respond to an evacuation alarm or verbal announcement.			
This information will be given to the Emergency Coordinator who will contact you to discuss your request and will notify other individuals that have assigned duties during an emergency. All information will be kept confidential pursuant to the Federal Privacy Act (P.L. 93-579).			
If you have any questions, please contact your emergency coordinator at: _____			
<b>Please remember: Your department cannot be responsible for your safety if you do not identify your needs for assistance.</b>			